

Best guess versus worst case

Deepwater disaster: how the oil spill estimates got it wrong

“There is no crude emanating from that riser.” Then the official estimate was 1000 barrels a day, then 5000. The true figure was 58 000 barrels of oil a day leaking into the Gulf of Mexico. Why did the authorities so consistently underestimate the flow from the *Deepwater* disaster, and what damage did those underestimates do? **Ian MacDonald** reveals the smoking gun behind BP’s erroneous statistics.

On April 20th, 2010, the explosion and sinking of a semi-submersible drilling rig called *Deepwater Horizon* killed 11 people and initiated a furious eruption of oil and gas from BP’s Macondo well, which was located in 1500 m of water 75 km southeast of Grand Island, Louisiana. The discharge was virtually unabated for 84 days until a steel cap was installed and successfully closed, staunching the flow completely, on 15th July. Emergency operations continued around the clock to drill a second, intercepting, shaft and install a final plug into the bottom of the blown-out well. When the people and equipment on *Deepwater Horizon*’s sister drilling rig *Development Driller III* threaded the needle and intercepted the Macondo borehole under sediment and rock 4000 m below the sea floor on 19th September, they brought the first act of an unprecedented environmental drama to an anticlimactic conclusion.

Because of the lives lost and the widespread ecological and economic damage, we need to determine what went wrong in all stages of the accident and the emergency response. We shall focus here on repeated confusion about one singular, all-important, and very

consequential variable in the ongoing emergency: the discharge rate of oil: that is, the number of barrels of oil per day gushing into the ocean far below the surface.

Official reports on the release and discharge rates were issued by authorities of the Unified Command, which was an often uneasy alliance between BP and the US government represented by no less than four cabinet-level departments (of Commerce, Energy, Homeland Security, and the Interior). Unfortunately, it took these authorities a very long time to get the rate right (Table 1).

The first sighting of a floating oil slick coming from the sunken rig was blamed on diesel fuel escaping from the rig [9]. Initially, the authorities apparently assumed that an emergency valve called a “blow-out preventer” had closed off the well at the seafloor. They stated flatly that no oil was discharging from the well.

On April 25th, the estimate was 1000 barrels of oil per day (bopd). By August 2nd, weeks after the oil had stopped flowing, the estimate had risen to 58 000 bopd. The trend of increasing estimated rates, and the increasing perception of possible grave consequences for the

BP used bad estimates of the size of the spill to reject their own much better ones

Table 1. Estimates of oil discharge rate from BP well. These estimates were given in press statements from spokespeople representing Unified Command: Coast Guard Rear Admiral Mary Landry, Coast Guard Admiral Thad Allen, and Dr Marcia McNutt speaking for the Flow Rate Technical Group. Estimated rates are median values in barrels of oil per day (bopd). The estimated release is the total barrels that would have issued from the well between April 22nd and July 15th, 2010, had the estimated rate been accurate. Release is defined as oil and gas that leaves the reservoir. Discharge is oil and gas that escapes into the environment. Discharge is less than release because BP were eventually able to capture a total of 800 000 barrels of oil and a large amount of gas before it escaped. Exxon Valdez (EV) units quantify the BP discharge relative to the official discharge of 250 000 barrels (10.8 million gallons) from the 1989 disaster.

Date 2010	Authority	Estimated rate (bopd)	Estimated release	Estimated discharge	EV units	Ref.
Apr. 23	Landry	0	0	NA	NA	1
Apr. 25	Landry	1 000	84 000	NA	NA	2
Apr. 28	Landry	5 000	420 000	NA	NA	3
May 1	Allen	Accurate estimate impossible	NA	NA	NA	4
May 27	McNutt	16 000	1 344 000	544 000	2.1	5
June 10	McNutt	30 000	2 520 000	1 720 000	6.7	6
June 15	McNutt	48 000	4 032 000	3 232 000	12.6	7
Aug. 2	McNutt	58 000	4 872 000	4 072 000	15.8	8

ecosystem and people of the region, are obvious from Table 1. The facts show that during the first five weeks or more of the emergency, the official rate of release grossly underestimated the true rate that would eventually be determined. Particularly troubling is the interval from April 28th to May 27th – a complete month during which authorities were responding to an estimated release rate of 5000 bopd, which was more than an order of magnitude lower than the true rate as efforts went forward. Clearly this estimate must have hampered effective relief. Where did this erroneous and far-too-low estimated rate come from, and why was it allowed to stand for so long?

Getting the rate wrong

Consider the circumstances that faced the responders assessing the situation at the exploded well during the waning days of April. Exploration by the indispensable robot submersibles had discovered that oil was discharging from three locations amid the twisted tangle of pipes and other debris that collapsed to the sea floor when the rig sank. There were small but very powerful jets coming from perforations on the main 20-inch riser pipe where it made a sharp bend on the top of the 60 ft high blow-out preventer (see Figure 1(b), page 152); there was a huge billowing gusher from a broken section of the riser where it lay in a crater about 400 ft from the well; and there was a smaller jet from the drill pipe at what had been the upper end of the riser, now at rest about 900 ft from the well. To estimate the total discharge, responders had three options,

listed in roughly descending order of reliability: (1) use technical means – seabed sensors and videos – to quantify the flow from the discharging jets; (2) model from the geological and engineering data already known about the reservoir and well from the exploration drilling that *Deepwater Horizon* had completed just before the accident; or (3) quantify the amount of oil arriving at the surface of the ocean, and back-calculate a discharge rate from that.

Eventually, the authorities would come to rely on methods (1) and (2), analysing video footage from cameras on remotely operated submersible vehicles with a quantitative visual technique called particle imaging velocimetry^{8,10} and augmenting reservoir data with an extensive sensor array. Their stance in late April and early May was quite different. The Unified Command initially chose to ignore what they might have learned from analysing the jetting oil plumes. Thad Allen, Incident Commander, proclaimed on May 1st that “any exact estimation of what’s flowing out of those pipes down there is probably impossible at this time due to the depth of the water and our ability to try and assess that from remotely operated vehicles and video”⁴. Other experts were capable of and would eventually succeed in producing accurate estimates of the discharge rate based on even low-quality video of the oil jets¹¹, but until 13th May BP categorically refused to release publicly any of the copious video footage it recorded at the sea floor.

The authorities took the public position that accurate assessment of the discharge rate was unneeded, because they were already responding with maximum effort and effect and

because such efforts might actually interfere with other response activity. Privately, BP and the National Oceanic and Atmospheric Administration (NOAA) were conducting discharge assessments using well models and remote sensing. Remarkably, my review of the records suggests that the authorities would come to constrain the results of reservoir and well modelling using for their constraint erroneous results from the least reliable method – remote sensing evaluation of surface oil. To understand how they went wrong, we need a little background on oil pollution at sea.

Oil on water

Oil famously does not mix with water. A light, low-sulphur crude oil like that from the Macondo well will rapidly spread into thin layers on the surface of the ocean. Evaporation and other processes will consume about one-third of the floating oil over the course of a few days, but initially the appearance of the oil is well correlated to its thickness. There is a long history of study on this topic, and the North Sea states, including Britain, are signatories to the Bonn Agreement. Under this authority, oil spill responders are supposed to describe oil floating on the ocean by a standard nomenclature and classify its thickness¹². The United States is not a signatory to the Bonn Agreement, but the NOAA conforms to Bonn standards in its useful field guide for judging the amount of oil released by pollution events¹³. The thinnest possible oil layers are called “sheen”;

An oil layer, thinner than a hair, over thousands of square km makes a huge volume

they are no more than a few molecules thick. Thinner than the wavelength of visible light, they are detectable only because they dampen small ripples and give the water an enhanced reflective appearance. Somewhat thicker oil layers, called “rainbow”, become visible when they refract light over a few multiples of the visible range: these layers are about 0.5 to 5 µm thick. Heavier oil begins to show “metallic”, “discontinuous” and “true” colours in layers of 10 to more than 100 µm. For comparison, a human hair has a diameter of about 100 µm, so “coloured” oil is still a very thin layer, but when spread over hundreds or thousands of square kilometres the volume becomes large.

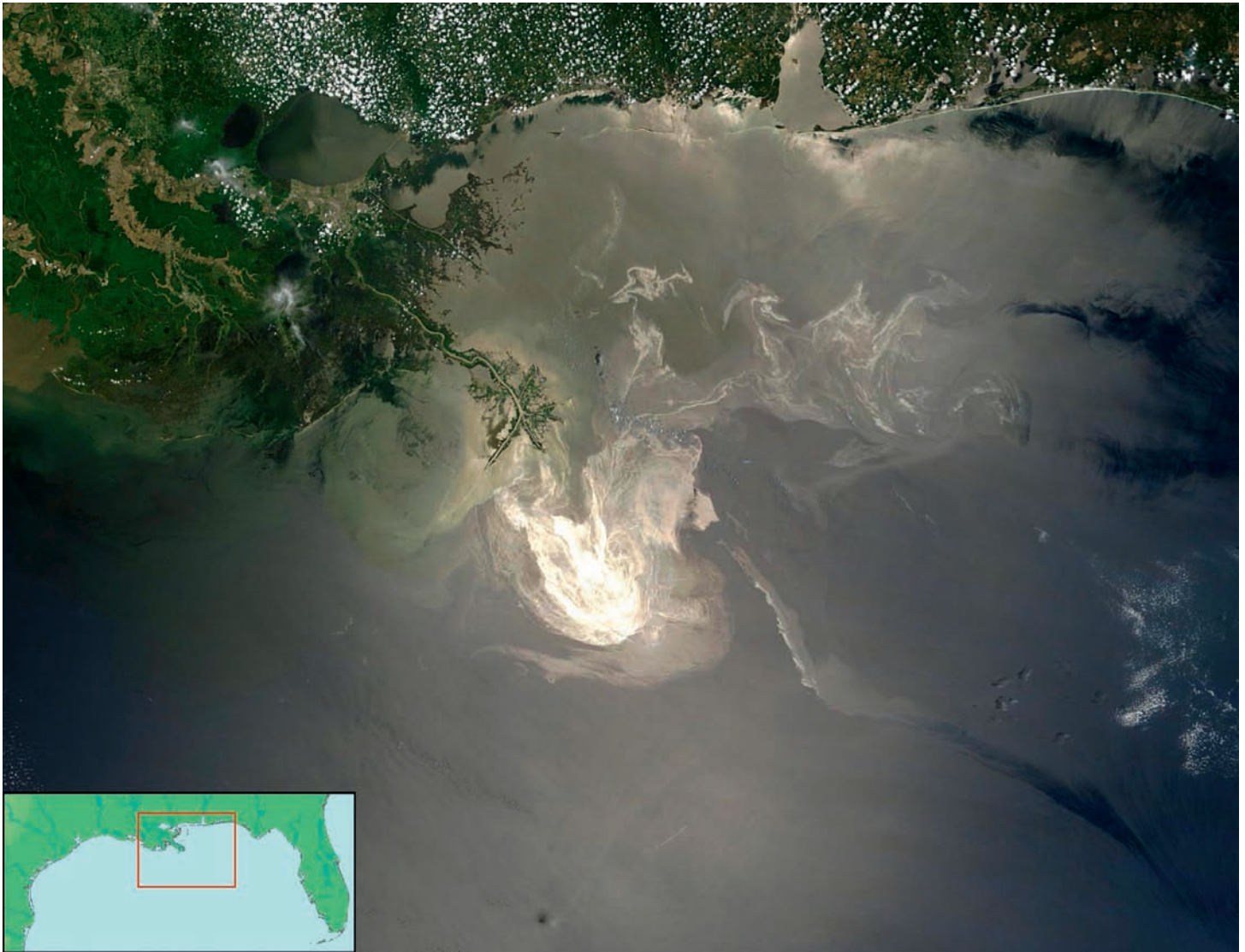

The *Deepwater Horizon* oil spill as seen by NASA's Terra satellite, May 24th, 2010. Courtesy NASA/JPL-Caltech

Here I should note that my public profile in the BP oil discharge story stems from back-of-an-envelope estimates I made in late April along with my colleague John Amos. Although no one in the public yet had access to the video of oil jetting from the pipes, we could access a variety of satellite images of the surface oil. From previous work on remote sensing of natural oil seeps in the Gulf of Mexico, I had in my memory a trivial formula:

$$1 \mu\text{m} \times 1 \text{km}^2 = 1 \text{m}^3$$

This allowed me easily to convert the area of the spreading oil into volume and piqued my concern when I saw the area increasing rapidly in successive images. By combining the satellite images with the Coast Guard's description of the oil appearance, and consulting the NOAA field guide for appropriate thicknesses, I estimated that the *minimum* rate of discharge had to be 26500 bopd. Because I did not account for evaporation or other losses, the actual rate

might well be significantly greater. I said this in a blog on April 27th¹⁴. It would be a number of nervous weeks for us before the official rates caught up with me and John – nervous because I had publicly staked my reputation on a rate much greater than the official one and because BP would not release the video to confirm or refute what we were saying. What I did not know then was that BP had also looked at remote sensing data and had come up with an estimate (as we now know, a far too low one) close to the 5000 bopd rate given by the authorities. These estimates apparently contributed to an officially sanctioned foundation on which public announcements were based.

Behind the scenes

Technicians working for BP made a series of estimates of discharge rates beginning on April 27th, looking at data similar to that which John Amos and I had reviewed but coming up

with very different results. Their results were summarized in confidential memos numbered CE02095 to CE02099, which were obtained by Representative Edward Markey, who then had his staff copy them to me for independent evaluation. Figure 1(a) reproduces the first memo of the series. In it, the technicians identify three classes of oil – sheen, dull and dark – and make their calculations, in imperial units based on variables of “area”, “cover factor” (%) and “gal/sq mi”. Multiplying through gives the volume in gallons for each of the oil classes, and dividing by days of discharge gives the instantaneous rate. Unlike my estimate, these analysts compensate for evaporation and dissipation by using a multiplier of 2, meaning that they assumed that half of the oil discharged had disappeared by April 26th, four days after the spill began. The “best guess” was 5768 bopd. The other memos in the series CE02096 to CE02099 give best guess estimates of 5092, 5906, 5226 and 5707, respectively. A final memo from an unnamed

NOAA technician also estimates 5000 bopd, assuming that most of the oil is sheen with a thickness of 0.1 µm. Why was this estimate so low, given that the technicians were looking at the same data as John and myself?

The worksheets claim that the authority for this procedure was taken from an ASTM standard¹⁵ and not from the NOAA guidelines that I have described previously. Careful review of this standard finds that a key parameter used by the BP technicians, “gal/sq mi”, does not appear in it. The ASTM standard notes that the thickness of floating oil layers (in micrometres) can be judged from the colour and appearance of oil on water. The standards caution: “the only physical change in appearance that is reliable is the onset of rainbow colours, at 0.5 to 3 µm thickness”.

If the “gal/sq mi” parameter is recalculated in the accepted units of micrometres (Table 2) it is evident that the parameters for oil class thickness do not in fact match the ASTM standards, which in any event do not provide reliable guidance for layers thicker than 3 µm. Nor do they match the NOAA field manual.

The guidelines that were actually used by the BP technicians were at least partially taken from BP’s official *Regional Oil Spill Response Plan – Gulf of Mexico*¹⁶. This document has already been criticised because it includes protection plans for sea otters and walruses – neither of which exist in the Gulf of Mexico. Possibly more serious however is the table in Section 1D of the *Plan*, which is entitled “Oil thickness estimations”. This set of standards uses the same gallons per square mile multiplier as is found in the BP worksheets, but the table in the plan also gives equivalent thicknesses in micrometres. Comparison of the BP table with the NOAA and Bonn standards (Table 3) shows that the BP technicians were using oil thicknesses that were as much as 100 times smaller than what is prescribed by the Bonn Agreement and NOAA guidelines. So the “best guess” was obtained using guidelines that were biased toward results much lower than would have been obtained by using accepted standards. Tellingly, if the discharge rates based on oil on water are recalculated but taking layer thickness estimates from the NOAA field guide and revising downward the rate at which oil evaporates and dissipates, the low, best guess, and high estimates increase by a factor of 5 or more (Table 2.)

The second method used by the BP team to estimate discharge relied on what they knew about the reservoir, the flow capacity of the pipes used, and evaluation of the condition of the reservoir and well components (Figure 1b).

BP and NOAA Emission Rate Estimates From Rep. Markey

Using “Standard Guide for Visually Estimating Oil Spill Thickness on Water, ASTM F 2534 - 06.”

ATTACHMENT 1

Oil on Water Estimate - Low					Oil on Water Estimate - Best Guess					Oil on Water Estimate - High							
	sq mi	Cover Factor	gal/sq mi	gals	bbbs		sq mi	Cover Factor	gal/sq mi	gals	bbbs		sq mi	Cover Factor	gal/sq mi	gals	bbbs
Sheen	1500	0.5	50	37500	893	Sheen	1500	0.66	333	329670	7849	Sheen	1500	0.75	666	749250	17839
Dull oil	250	0.2	666	33300	793	Dull oil	250	0.35	1332	116550	2775	Dull oil	250	0.5	3330	416250	9911
Dark oil	9	0.15	3330	4495.5	107	Dark oil	9	0.25	6660	14985	357	Dark oil	9	0.35	13320	41958	999
Total oil on water				75295	1793	Total oil on water				461205	10981	Total oil on water				1E+06	28749
x 2 to compensate for evap and disp				3588		x 2 to compensate for evap and disp				21962		x 2 to compensate for evap and disp				57498	
recovered				200		recovered				450		recovered				700	
chemically dispersed				1000		chemically dispersed				3500		chemically dispersed				6000	
Total emitted				4786		Total emitted				25912		Total emitted				64198	
Barrels emitted per day				1063		Barrels emitted per day				5758		Barrels emitted per day				14286	

(a)

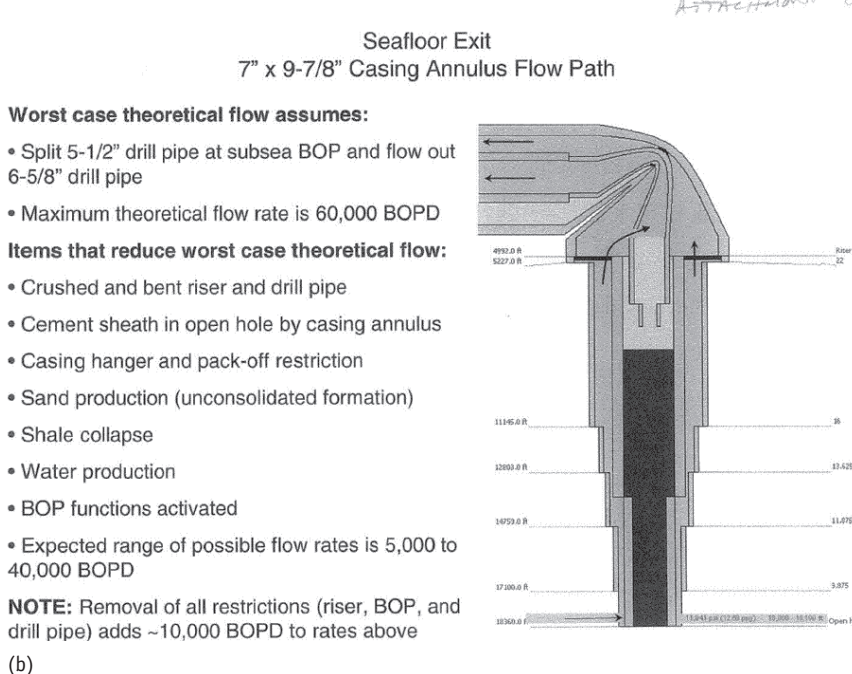

(b)

Figure 1. Facsimile copies of discharge rate estimates calculated by BP technicians between about April 27th and May 1st, 2010. (a) Estimates of discharge rate calculated from oil on water measurements. (b) Range of discharge rates taken from reservoir properties and assessment of the well damage.

Table 2. Discharge rate estimates taken from oil on water (Figure 1(a)), converting “gal/sq mi” to micrometres. BP’s low, best guess and high rate estimates (bopd) were calculated from these thickness values multiplied by a factor of 2 to allow for removal by dissipation and evaporation of oil over four days. The discharge rates are recalculated using thickness estimates taken from the NOAA field manual¹⁴ and assuming different dissipation factors (2, 1.7, 1.4). Revision yields higher rate estimates in all categories.

Rate estimate (barrels oil per day)	Oil class thickness (sq km)	Low µm (cover %)	Best guess	High
BP’s rate	Sheen (3900)	0.07 (50)	0.49 (66)	0.97 (75)
	Dull oil (650)	0.97 (20)	1.95 (35)	4.87 (50)
	Dark oil (23)	4.87 (15)	9.73 (25)	19.5 (35)
			1063	5758
Revised rate	Rainbow (3900)	0.30 (50)	1.65 (66)	5.00 (75)
	Dull oil (650)	5.00 (20)	26.5 (35)	50.0 (50)
	Dark oil (23)	50.0 (15)	125 (25)	200 (35)
		4194	26931	64866

Table 3. Oil on water appearance descriptions and thickness estimates for two pollution observation protocols. The Bonn Agreement is the standard in use by the North Sea states¹³. The BP *Regional Oil Spill Response Plan – Gulf of Mexico*¹⁷ was the protocol submitted by BP and accepted by the US Minerals Management Service as part of the company's comprehensive plan for offshore oil production in the Gulf of Mexico.

<i>Bonn Agreement</i>		<i>BP Regional Oil Spill Response Plan</i>	
<i>Oil appearance</i>	<i>Thickness (µm)</i>	<i>Oil appearance</i>	<i>Thickness (µm)</i>
Sheen	0.04–0.3	Barely visible	0.04
Rainbow	0.3–5.0	Silvery	0.08
Metallic	5.0–50.0	Slight colour	0.15
Discontinuous true colour	50–200	Bright colour	0.3
True colour	>200	Dull	1.0
		Dark	2.0

This memo, CE020102, follows the sequence of estimates from oil on water evaluation. Here they state plainly that the maximum theoretical discharge from the reservoir through the specified pipe sizes would be 60 000 bopd. On a second page of the memo (not shown) they allow that if discharge were restricted only by the maximum pipe size, it could amount to

100 000 bopd. Given this range of grave possibilities, responders would put forward the most optimistic – 5000 bopd.

Consequences

It is impossible for the public to know exactly what transpired within the Unified Command

and privately among the BP technical and public relations staff. Recent documentation suggests that requests by NOAA to inform the public of the worst case discharge rates were quashed by the White House¹⁷. The events of April to July 2010 are rapidly entering the legal arena, from which it will take years for the truth to emerge, if it ever does. The facts at hand do show, however, that the authorities initially presented the public with an apparent consensus opinion regarding the rate of discharge. This rate was lower than the present best estimate by an order of magnitude. In choosing to believe this rate, the authorities ignored the strongly contradictory evidence offered by videos of jetting oil and refused to consult independent experts who could have provided better analyses. Indeed, BP resisted releasing video for many weeks until forced to do so by threat of Congressional subpoena¹⁸. They also chose to overlook the stark warning from BP's own engineering team. This warning, of the "worst case" discharge rate of 60 000 bopd (Figure 1(b)), is eerily close to the final accepted discharge rate.



Deepwater Horizon offshore drilling unit on fire. Courtesy United States Coast Guard

Instead, they relied on remote sensing analysis based on non-standard evaluations regarding oil on water – highly questionable evaluations, in my view. Even here, with use of more realistic oil thickness and evaporation rate estimates, the remote sensing data should have warned the team that they were guessing much too low.

One issue going forward is this: what authority are responders actually required to use in evaluating marine oil pollution in US waters? Because the USA is not part of a treaty like the Bonn Agreement it appears that, for the moment, setting the legal standard for quantifying thickness of oil on the ocean falls between a patchwork of government agencies. Many oil companies operating in the Gulf of Mexico have subcontracted the job of formulating oil spill response plans to consulting companies. The BP *Regional Oil Spill Response Plan* is virtually identical to plans on file from a number of other companies – walrus and all. It would be good to supersede the oil on water standards in these plans at the very least.

The real question is this: did the low-ball estimates during the first month of the emergency do any harm? In my view they did – although I am certain that this judgement would be vigorously disputed by the Unified Commanders. Consider each of the many interim measures taken in response during the first half of the event. In May a containment dome was placed above the riser. It could not handle the rate of flow and within less than an hour became clogged with gas hydrate ice. The riser tube insertion tool produced the darkly comical result of capturing almost 5000 bopd at a time when BP was insisting on 5000 bopd as a top rate, while the video (which was by then on-line full time) showed an apparently undiminished gusher of oil. The “top kill” attempt to plug the well with drilling mud did not succeed because of the enormous pressure of the oil and gas discharge. The “top hat” installed in July was too small. And finally, when by dogged endeavour the responders succeeded in hooking up recovery lines so they could capture oil before it discharged into the ocean, it turned out that the maximum recovery capacity of the ships on station – at this point about two months after the accident – was only a quarter of the actual release rate: 15 000 as opposed to 58 000 bopd. The lower figure can be found in the oil on water estimates labelled “high” – yet it was clearly far too low. In my opinion, the consequence of low estimates was a longer duration of the oil discharge.

It was only when the Flow Rate Technical Group began to have credible numbers for discharge and reservoir pressure and trends

over time that the responders gained the confidence to unbolt the broken flange and bolt a new, closable cap in place to shut off the discharge. This solution was actually proposed in the very early days of the emergency¹⁹, but was not adopted because the responders feared it would make the situation worse; they did not believe that they were already experiencing their worst case scenario.

Far from harming the response effort, accurate rate estimates proved crucial to the final solution. This is undoubtedly why the BP *Regional Oil Spill Response Plan – Gulf of Mexico* states that: “When a spill has been verified and located, the priority issue will be to estimate and report the volume and measurements of the spill as soon as possible.” Determining the pump or spill rate by direct measurements is the preferred method. The Coast Guard and the Minerals Management Service have similar blow-out guidelines. If only they had followed their own advice.

References

1. Johnson, A. (2010) *No crude oil leaking from Gulf well: US Coast Guard*. AFP, April 22nd. <http://bit.ly/dAiVv6>
2. Robertson, C. (2010) Oil leaking underwater from well in rig blast. *New York Times*, April 24th. <http://www.nytimes.com/2010/04/25/us/25rig.html>
3. Robertson, C. and Kaufman, L. (2010) Size of spill in Gulf of Mexico is larger than thought. *New York Times*, April 28th. <http://www.nytimes.com/2010/04/29/us/29spill.html>
4. MarineLog (2010) *Press Briefing by Coast Guard Commandant Thad Allen, and Assistant to the President for Homeland Security John Brennan on ongoing response to oil spill*. Deepwater Horizon Response, May 1st. <http://www.marinelog.com/DOCS/NEWSMMIX/2010may00010.html>
5. U.S. Dept. Interior (2010) *Flow Rate Group provides preliminary best estimate of oil flowing from BP oil well*. Deepwater Horizon Response, May 27th. <http://www.doi.gov/news/pressreleases/Flow-Rate-Group-Provides-Preliminary-Best-Estimate-Of-Oil-Flowing-from-BP-Oil-Well.cfm>
6. U.S. Dept. Interior (2010) *Admiral Allen; Dr. McNutt provide updates on progress of scientific teams analyzing flow rates from BP's well*. Deepwater Horizon Response, June 10th. <http://www.doi.gov/news/pressreleases/Admiral-Allen-Dr-McNutt-Provide-Updates-on-Progress-of-Scientific-Teams-Analyzing-Flow-Rates-from-BPs-Well.cfm>
7. U.S. Dept. Interior (2010) *U.S. scientific team draws on new data, multiple scientific methodologies to reach updated estimate of oil flows from BP's well*. Deepwater Horizon Response, June 15th. <http://www.doi.gov/news/pressreleases/Flow-Rate-Team-Updates-Estimate-of-Oil-Flowing-from-BP-Well.cfm>
8. U.S. Dept. Interior (2010) *U.S. scientific teams refine estimates of oil flow from BP's well prior to capping*. Deepwater Horizon Response, August 2nd. <http://www.doi.gov/news/pressreleases/US-Scientific-Teams-Refine-Estimates-of-Oil-Flow-from-BP-Well-Prior-to-Capping.cfm>
9. CNN Wire, Coast Guard: oil rig that exploded has sunk. CNN 2010. April 22, 2010 (<http://news.blogs.cnn.com/2010/04/22/coast-guard-oil-rig-that-exploded-has-sunk>).
10. Crone, T. J. and Tolstoy, M. (2010) Magnitude of the 2010 Gulf of Mexico oil leak. *Science*. doi:10.1126/science.1195840.
11. Harris, R. (2010) *Gulf spill may far exceed official estimates*. National Public Radio Morning Edition, May 14th. <http://www.npr.org/templates/story/story.php?storyId=126809525>
12. Bonn Agreement (2007) *Bonn Agreement Aerial Surveillance Handbook*. <http://bit.ly/a8wJeq>
13. NOAA Hazmat (2007) *Open water oil identification job aid for aerial observation*. Office of Response and Restoration. <http://bit.ly/dtIHic>
14. MacDonald, I. R. and Amos, J. F. (2010) *Gulf oil spill rate must be much higher than stated – 6 million gallons so far?* Skytruth Blog, April 27th. <http://blog.skytruth.org/2010/04/gulf-oil-spill-rate-must-be-much-higher.html>
15. ASTM International (2006) *Standard guide for visually estimating oil spill thickness on water*. In *ASTM Committee F20 on Hazardous Substances and Oil Spill Response*. West Conshohocken, PA: ASTM International.
16. BP (2009) *Regional Oil Spill Response Plan – Gulf of Mexico*. GoM EMS Mgmt Representative. UPS-US-GOM-HSE-DOC-00177-2. <http://publicintelligence.net/bp-gulf-of-mexico-regional-oil-spill-response-plan/>
17. National Commission, *The amount and fate of the oil*. National Commission on the BP Deepwater Oil Spill and Offshore Drilling, 2010. October 6, 2010.
18. Markey staff, personal communication.
19. Suttles, D. (2010) Oral testimony. BP Deepwater Horizon Oil Spill and Offshore Drilling, Meeting 3, Day 1. <http://www.oilspillcommission.gov/>

Ian R. MacDonald is a Professor of Oceanography at Florida State University. He specialises in using imaging and geographic information system techniques to investigate the ecology of deep-sea hydrocarbon seeps, primarily in the Gulf of Mexico.